

CILINDRO HIDRAULICO 3º PONTO - TRAVÃO

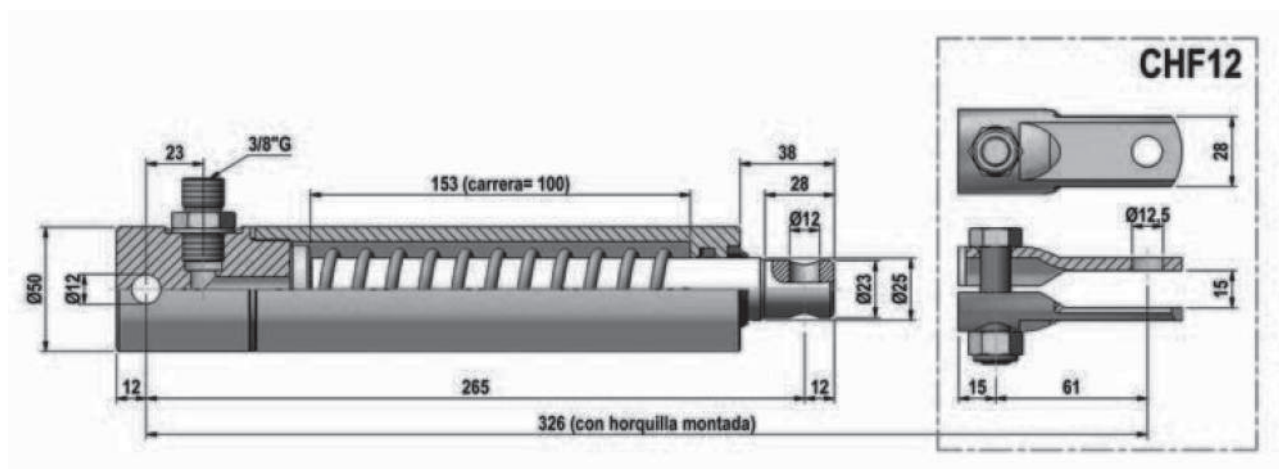

Opcional:
Ponteira Ref.: CHF12

| REF. | Ø haste | Course | Ø Ext | Vol. (l) | Peso (kg) |
|-----------|---------|--------|-------|----------|-----------|
| 2550100RN | 25 | 100 | 50 | 0,12 | 3,05 |

| REF. | Descrição |
|--------|--|
| 0450-2 | Tubo R2AT 3/8" 0,45mts. + fêmea giratória 3/8" a 90° + fêmea direita 1/2". |

Opcional:
Conjunto Tubo Flexível



Palonnier

| REF. | Ø A | Curso | Peso (kg) |
|-------|-----|-------|-----------|
| VFP25 | 25 | 110 | 4,47 |
| VFP30 | 30 | 110 | 4,93 |
| VFP35 | 35 | 110 | 5,50 |

